

Hiab XS 088

Range 6-9 tm



Hiab XS 088 Basic data

Technical data	B-3 CL	B-2 Duo	E-4 HiDuo	E-5 HiDuo
Max. lifting capacity (kNm)	65	69	71	68
Outreach, hydraulic extensions (m)	9.7	7.7	11.6	13.7
Outreach, manual extensions (m)	11.8	11.8	13.7	-
Outreach / lifting capacity (m / kg)	3.1 / 2300	2.9 / 2700	2.2 / 3500	2.2 / 3250
	3.9 / 1700	3.8 / 2000	4.2 / 1860	4.3 / 1760
	5.5 / 1160	5.4 / 1380	5.8 / 1260	5.9 / 1180
	7.3 / 840	7.3 / 1020	7.7 / 900	7.8 / 820
	9.2 / 660	-	9.6 / 700	9.7 / 600
Slewing angle (°)	400 - 406	400 - 406	400 - 406	400 - 406
Height in folded position (mm)	2000	2000	2000	2000
Installation space needed (mm)	765	685	720	785
Weight, "standard" crane without stabilizers (kg)	1170	1080	1260	1340
Weight, stabilizer equipment (kg)	140 - 275	140 - 275	140 - 275	140 - 275

XS 088 HiDuo

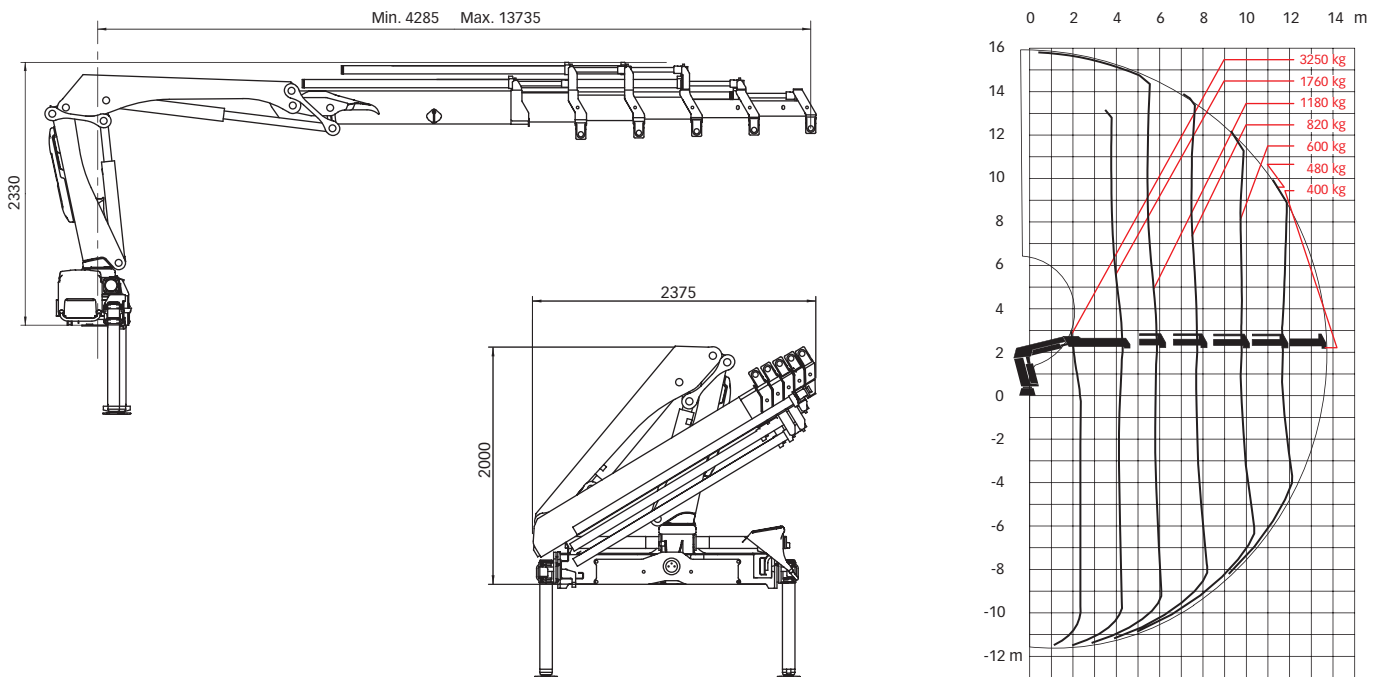

Disclaimer Hiab cranes have been built to meet the highest standards of safety and service life and have been thoroughly tested. Strength calculations for this model have been carried out in accordance with EN13001 in fatigue class S2. Cargotec's certified Quality Assurance System complies with ISO 9001. Some of the items in our literature may be extra equipment. Certain applications may require an official permit. We reserve the right to change technical specifications without prior notice. Hiab cranes produced for EU-countries are CE-marked and comply with the European Standard EN 12999.

Cargotec improves the efficiency of cargo flows by offering solutions for the loading and unloading of goods on land and at sea – wherever cargo is on the move. Cargotec's main daughter brands for cargo handling Hiab, Kalmar and MacGregor are global market leaders in their fields. www.cargotec.com